



# SALTDogg<sup>®</sup>

## S P R E A D E R S

### UNDER TAILGATE SPREADERS

HYDRAULIC DRIVE OR ELECTRIC DRIVE

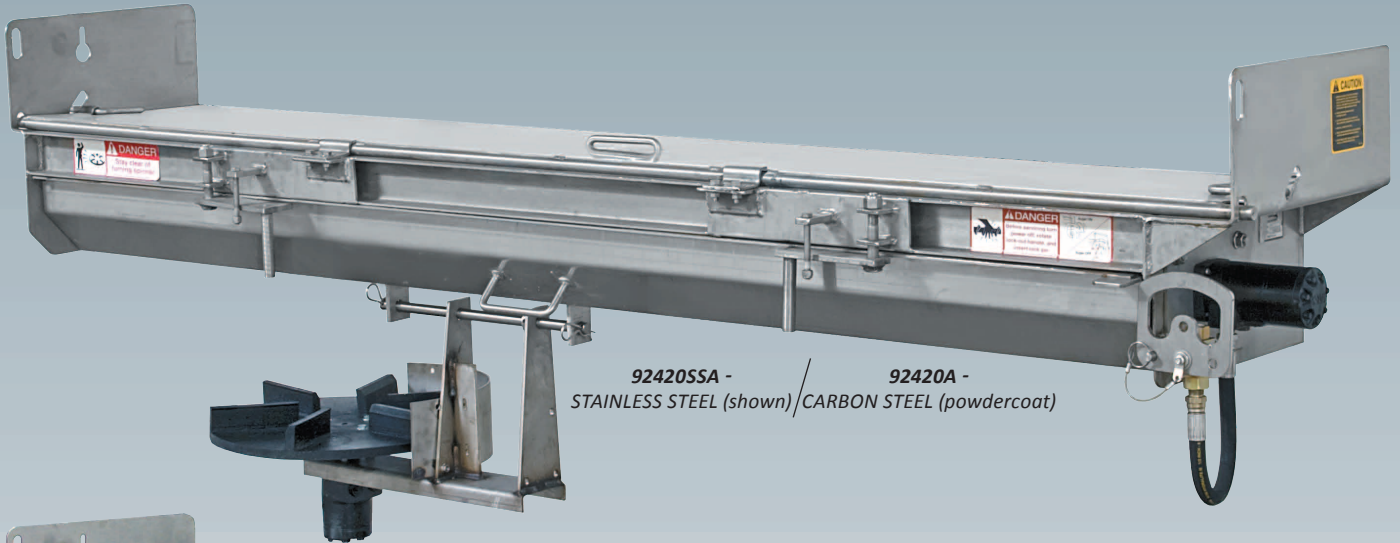

92420SSA - STAINLESS STEEL (shown) / 92420A - CARBON STEEL (powdercoat)



92440SSA - STAINLESS STEEL (Shown)

PART NO.	DESCRIPTION	WT.
92420A	96" Direct Drive Under Tailgate Spreader, Orange Powder Coat Finish	510 lbs.
92420SSA	96" Direct Drive 304 Stainless Steel Under Tailgate Spreader	392 lbs.
92430A	96" Under Tailgate Spreader w/5:1 Reduction Ratio Gearbox, Orange Power Coat Finish	551 lbs.
92430SSA	96" Under Tailgate Spreader w/5:1 Reduction Ratio Gearbox, 304 Stainless Steel	405 lbs.
<b>NEW</b> 92440SSA	96" Electric Drive 304 Stainless Steel Under Tailgate Spreader	575 lbs.

**HYDRAULIC DRIVE**

- Direct drive operation reduces number of moving parts, assuring dependable service.
- Under tailgate mounting allows normal use of dump body without interference from spreader.
- Rugged 7-gauge trough has 3-point hinged bottom cover that provides easy access to entire auger assembly for easy, one-person cleanout.
- Spreads from 4' to 40' of rock salt, free-flowing granular materials or chemicals.
- Auger is supported by 1-1/4" steel shaft ends and has right and left flighting to the discharge port delivering a continuous, consistent flow of spreading material.
- Sealed, self-aligning 1-1/4" diameter radial bearings with grease fittings.
- Low-speed, high-torque orbital motors.
- Spreader assemblies come with material trough, auger assembly, spinner and auger motors, spinner assembly, 18" polyurethane spinner and mounting plates.
- Hydraulic safety lockout system.
- Heavy-Duty 5:1 gearbox model increases the torque at the auger.
- Stainless steel model includes stainless steel mounting brackets.
- Poly adapter for auger motor improves serviceability.

**HYDRAULIC DRIVE ACCESSORIES & REPLACEMENT PARTS:**

PART NO.	DESCRIPTION
<b>924F0106PR</b>	Tailgate Side Shields, Black Powder Coat
<b>924F0106SSPR</b>	Tailgate Side Shields, Stainless Steel
<b>HV715</b>	Dual-Flow Regulator Valve
<b>HVC1</b>	Dual-Flow Regulator Valve Console
<b>SMR15S</b>	15-Gallon Reservoir
<b>SMR25S</b>	25-Gallon Reservoir
<b>9240089</b>	5:1 Reduction Ratio Gearbox
<b>CM004P</b>	Spinner Motor (Direct Drive)
<b>CM074P</b>	Auger Motor (Direct Drive)
<b>CM034P</b>	Auger Motor (Gearbox)
<b>9242001A</b>	Spinner & Hardware Replacement Kit, CS
<b>3006717A</b>	Spinner & Hardware Replacement Kit, SS
<b>3001472A</b>	Spinner Assembly, Poly 18" dia.
<b>924F0081AK</b>	96" Auger Kit — Includes Auger, Fliting, Pipe, Steel Shaft Ends, Bearing

**ELECTRIC DRIVE**

- Two ultra-quiet 12-volt DC direct-drive motors power the auger and spinner, and are encased in a heavy-duty poly housing. The wiring harness is constructed of 10-gauge automotive wire with non-combustible sheathing (-50°C to -105°C). An in-cab console features independent controls for the auger and spinner.
- Under tailgate mounting allows normal use of dump body without interference from spreader.
- Rugged 7-gauge trough has 3-point hinged bottom cover that provides easy access to entire auger assembly for easy, one-person cleanout.
- Spreads from 4' to 25' of rock salt, free-flowing granular materials or chemicals.
- Auger is supported by 1-1/4" steel shaft ends and has right and left flighting to the discharge port delivering a continuous, consistent flow of spreading material.
- Sealed, self-aligning 1-1/4" diameter radial bearings with grease fittings.
- Spreader assemblies come with material trough, auger assembly, spinner and auger motors, spinner assembly, 14" polyurethane spinner and mounting plates.
- Includes stainless steel mounting brackets.
- Poly adapter for auger motor improves serviceability.

Buyers Products Company reserves the right to change material, dimension and/or component specifications without notice.

**ELECTRIC DRIVE ACCESSORIES & REPLACEMENT PARTS:**

PART NO.	DESCRIPTION
<b>3013821</b>	Gear Motor Auger
<b>3014078</b>	Spinner Motor



92420SSA Shown Mounted on Truck

**CONTACT:**



Your Authorized SaltDogg® Distributor